

Interfacial Rheology of Gas/Liquid and Liquid/Liquid Interfaces

Philipp Erni, Peter Fischer, and Erich J. Windhab

Laboratory of Food Process Engineering, Institute of Food Science and Nutrition,
ETH - Swiss Federal Institute of Technology, CH-8092, Zürich, Switzerland

ABSTRACT

An interfacial shear rheometer for stress- and strain-controlled measurements at liquid interfaces is outlined. Experimental data are reported for the surfactant sorbitan tristearate on κ -carrageenan subphases. A setup combining interfacial rheometry with Brewster-angle Microscopy for realtime imaging of the interface is presented.

INTRODUCTION

Dynamic processes involving deformable fluid interfaces are not only influenced by the equilibrium interfacial properties (such as the thermodynamic interfacial tension) but also depend on the rate and deformation type at which an interface is deformed [1]. The field of interfacial rheology is usually divided into the subareas of shear rheology and dilational rheology.

We have recently described an interfacial shear rheometer based on the classical biconical bob design for use in both stress- (torque-) or strain-controlled modes at air/water or oil/water interfaces (see Fig. 1) [2]. By using a rheometer with a low friction electronically commutated (EC) motor in combination with the Direct Strain Oscillation (DSO) method, which allows to control the position of the disk in real-time [3], we are able to perform measurements at sufficiently low torques and deflection angles as necessary in interfacial rheometry. With this design, both stress and strain-

controlled experiments can be performed on the same interfacial film. Since the calculation of the interfacial shear viscosity and dynamic moduli is based on a full analysis [2, 4-5] of the flow in the rheometer (including subphase drag effects) it is possible to measure interfacial responses even in systems with a high subphase viscosity. In this contribution, we report on the interfacial shear rheology of sorbitan tristearate spread on κ -carrageenan subphases.

The fluid systems studied are (1) pure water/air, (2) κ -carrageenan/air and (3) κ -carrageenan/silicone oil. We show that with the instrumentation and the fluid mechanical analyses used for this work interfacial shear rheometry can be performed in systems with subphase viscosities some orders of magnitude larger than that of water.

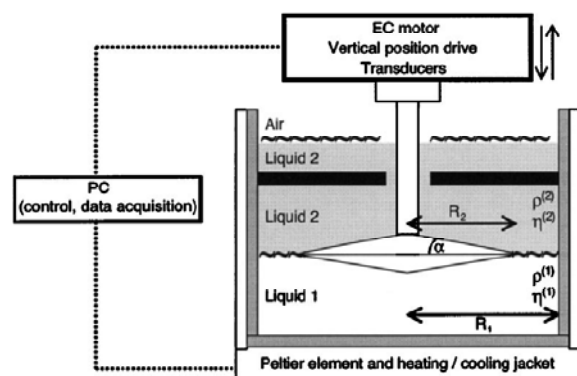

Figure 1. Schematic of the interfacial shear rheometer

EXPERIMENTAL

Materials

Sorbitan tristearate and chloroform (p.a.) were purchased from Fluka and used as received. All water used was purified with a Milli-Q® Biocel (Millipore) pure water system. Sodium κ -carrageenan was kindly provided by Unilever (Vlaardingen, The Netherlands). The bulk rheological properties of the biopolymer are virtually Newtonian in the range of concentrations, shear rates and stresses studied here [6]. Bulk viscosities of the biopolymer solutions used here are 71 mPas (1% w/w) and 143 mPas at 20 °C.

Silicone oil (AK 50) with a dynamic viscosity of 52 mPas at 20 °C was purchased from Wacker Chemie (Munich, Germany) and used as received. The interfacial tensions of the carrageenan subphases against air and against oil were measured at a temperature of 20 °C by drop volume tensiometry. For the κ -carrageenan (1.5% w/w) / silicone oil system, the equilibrium interfacial tension was 35.9 mN/m at a drop formation time of 280 s (for the pure water/silicone oil system we have measured an interfacial tension of 36.5 mN/m, therefore the biopolymer shows very small interfacial activity as compared to pure water, probably due to minor impurities). For the κ -carrageenan (1.5% w/w)/air system the equilibrium surface tension was 71.6 mN/m.

Interfacial shear experiments

All experiments are performed both in either stress or strain-controlled mode using a Physica MCR 300 rheometer (Anton Paar - Physica, Ostfildern, Germany) adapted for interfacial rheometry. A biconical disk is rotated or oscillated at a controlled torque or rate while the cup remains stationary. Experiments were performed in the following modes:

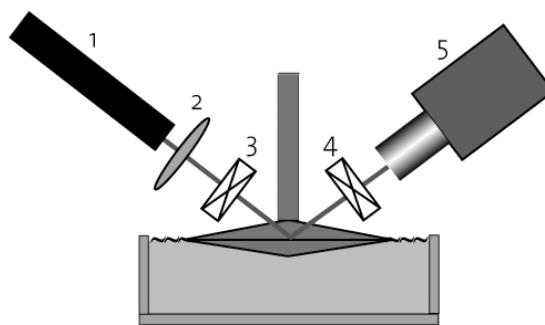

Figure 2. Schematic of the RheoBAM setup (1 Laser, 2 Beam expansion lens, 3 Polarizer, 4 Analyzer, 5 CCD camera).

(i) steady and oscillatory shear (both strain- and stress-controlled), (ii) creep (stress-controlled), (iii) stress-relaxation (strain-controlled). The instrument and the fluid mechanical background are described elsewhere [2].

Brewster-angle microscope (BAM)

BAM is used as an in situ technique for direct visualization of the structure, phase behaviour and orientation effects due to flow processes in interfacial films. The principle of a Brewster-angle microscope as well as the modified RheoBAM setup built in our lab are described in Refs. 6-9.

RESULTS AND DISCUSSION

We note that with the setup presented here the interfacial response can be extracted from the torque/deflection raw data even at high total disk torques (these may stem both from subphase viscosity or high shear rates). Further, strain amplitude sweep experiments with sorbitan tristearate on either pure water or on the biopolymer subphases show that the linear viscoelastic regime of the interfacial films is limited to very small strains (see Figs. 3 and 4).

Interfacial strain sweep experiments

The interfacial dynamic moduli G' and G'' measured at a κ -carrageenan/air interface are strain-independent only up to

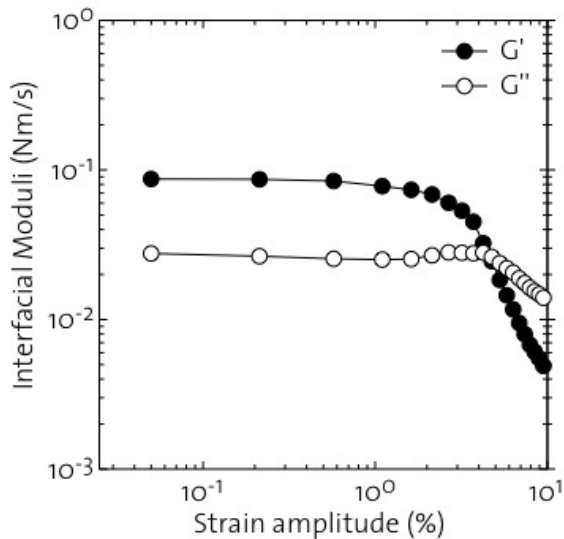

Figure 3. Strain sweep experiment with sorbitan tristearate ($0.35 \mu\text{g}/\text{cm}^2$) at the κ -carrageenan/air interface. (Oscillation frequency 1 s^{-1} , Temperature $20 \text{ }^\circ\text{C}$). Labels a – c correspond to the images shown in Fig. 4.

deformations as small as $\gamma = 3\%$. In Fig. 4 the morphology of the surface during such an experiment as monitored with BAM is shown. At subcritical deformations no changes in morphology are observed, but as soon as the critical deformation of around $\gamma=3.5\%$ is exceeded, a sudden fracture in the film occurs, resulting in a virtually unsheared portion of the surface with an intact film (left-hand side of Fig. 4c) and a ruptured portion of film fragments moving in a reduced shear gap (right-hand side of Fig. 4c).

Creep recovery tests

Creep recovery experiments were performed both on an uncovered surface of κ -carrageenan (1.5% w/w) and on surfaces covered with sorbitan tristearate (see Fig. 5). Note the scale of the deformation axis in both cases: while for the clean surface the disk of the rheometer would visibly rotate several times, only minor deformations $\gamma < 0.4 \%$ and the typical viscoelastic responses were observed for the

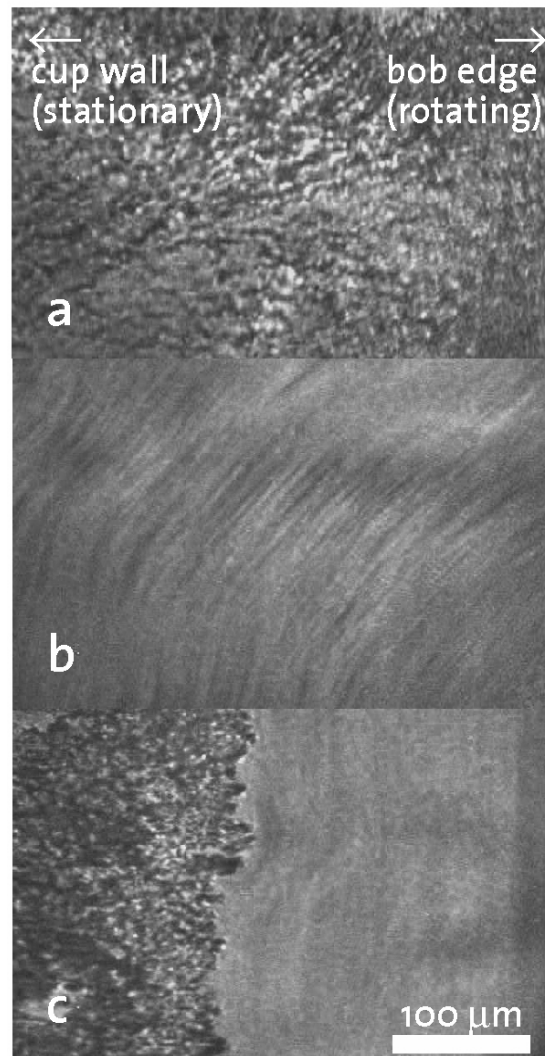

Figure 4. BAM images recorded during the amplitude sweep experiment shown in Fig. 4. (a) taken in the linear viscoelastic regime, (b) fracture of the film at a strain of $\gamma = 3.5 \%$ and (c) inhomogeneous flow pattern with an intact film on the left-hand side and debris of the ruptured film flowing in the reduced shear gap on the right-hand side.

surfactant-covered surfaces, including a phase of steady flow ($\partial\gamma/\partial t = \text{constant}$) and partial relaxation of the strain after the strain pulse has decayed back to zero. Performing a stress pulse as shown in Fig. 5 on a clean water surface will result in a completely different flow situation where deformations of much higher magnitudes will be measured. The disk of the rheometer would

visibly rotate several times if subjected to the same stress pulse on the surface of pure water, whereas the viscoelastic film in Fig. 5b is only slightly deformed.

Stress relaxation tests

A stress relaxation experiment performed with sorbitan tristearate at the interface between κ -carrageenan and silicone oil is shown in Fig. 6. The response of the interfacial relaxation modulus $G(t) = \tau(t)/\gamma_+$ to a step function of the strain to $\gamma_+ = 1.2\%$ at time $t = 0$ was measured.

DISCUSSION

It was shown that the rheological response of interfacial films may be obtained in surprisingly good quality even if subphases with viscosities higher than water are used. It should be noted that even with the analysis implemented here only the steady shear/oscillation experiments are based on a fully developed interfacial shear flow. For example, in the creep and relaxation experiments the calculated stresses are transient and should therefore be treated as effective interfacial stresses. While this is also true for similar tests in 3D rheology, the subphase flow adds a further degree of complexity to this problem. The steady shear flow and oscillatory flow problems have been solved [1-2, 4-6], while methods to calculate the interfacial and bulk flow fields under startup and relaxation conditions are still to be developed.

ACKNOWLEDGEMENTS

We thank Jörg Lauger, Victor Kusnezov and Patrick Heyer at Anton Paar – Physica for their support. The Food Process Engineering workshop at ETH was very helpful during the construction of the RheoBAM. This work was supported by the Swiss National Science Foundation (SNF project no. 2100-063976).

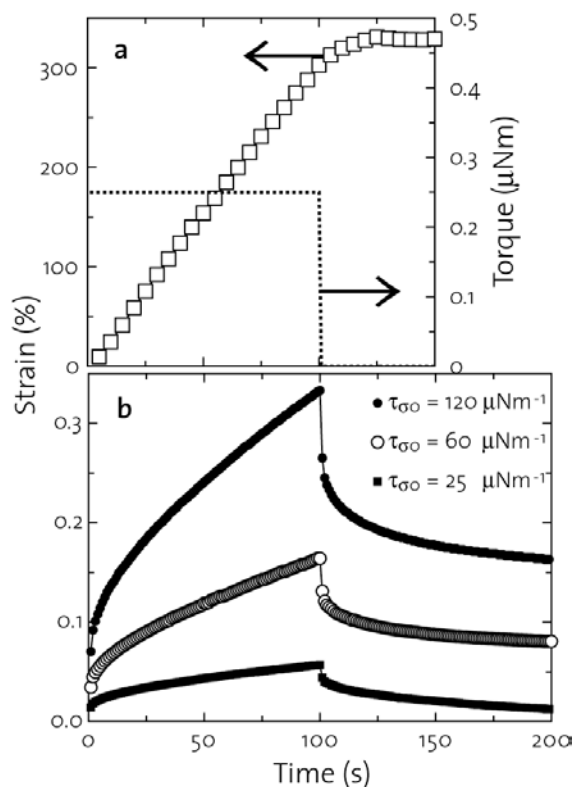

Figure 5. Creep tests – strain response to a stress pulse (a) Clean surface of a κ -carrageenan solution (1% w/w) (b) same subphase covered with sorbitan tristearate ($0.35\ \mu\text{g}/\text{cm}^2$) subjected to different interfacial shear stresses.

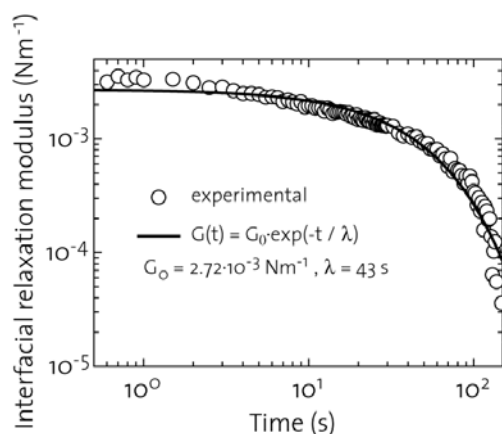

Figure 6. Interfacial stress relaxation from a strain step ($\gamma_+ = 0.8\%$ at $t = 0\text{ s}$). Sorbitan tristearate ($\Gamma_m = 0.35\ \mu\text{g}/\text{cm}^2$, interface between 1.5% (w/w) κ -carrageenan and silicone oil). A single mode Maxwell model is shown for comparison.

REFERENCES

1. Edwards, D.A., Brenner, H., and Wasan, D.T. (1991), "Interfacial Transport Processes and Rheology", Butterworth-Heinemann, Stonham, MA.
2. Erni, P., Fischer, P., Windhab, E.J., Kusnezov, V., Stettin, H. and Lauger, J. (2003) "Stress- and strain-controlled measurements of interfacial shear viscosity and viscoelasticity at liquid/liquid and gas/liquid interfaces", *Rev. Sci. Instrum.*, **74**, 4916-4924.
3. Lauger, J., Wollny, K., and Huck, S. (2002), "Direct Strain Oscillation: A New Oscillatory Method Enabling Measurements at Very Small Shear Stresses and Strains", *Rheol. Acta*, **41**, 356-361.
4. Oh, S.G. and Slattery, J.C. (1978), "Disk and Biconical Interfacial Viscometers", *J. Colloid Interf. Sci.*, **67**, 516-525.
5. Lee, H.O., Jiang, T.S. and Avramidis, K.S. (1991), "Measurements of Interfacial Shear Viscoelasticity with an Oscillatory Torsional Viscometer", *J. Colloid Interf. Sci.*, **146**, 90-122.
6. Erni, P., Fischer, P., Heyer, P., Windhab, E.J., Kusnezov, V., and Lauger, J. (2003) "Rheology of Gas/Liquid and Liquid/Liquid Interfaces with Aqueous and Biopolymer Subphases", *Progr. Colloid Polym. Sci.* (accepted, in press).
7. Henon, S., and Meunier, J. (1991), "Microscope at the Brewster Angle: Direct Observation of First-Order Phase Transitions in Monolayers", *Rev. Sci. Instrum.* **62**(4), 936-939.
8. Honig, D., and Mobius, D. (1991), "Direct Visualization of Monolayers at the Air-Water Interface by Brewster Angle Microscopy", *J. Phys. Chem* **95**, 4590-4592.
9. Fischer, P., Brooks, C. F., Fuller, G. G., Ritcey, A. M., Xiao, Y., and Rahem, T. (2000). , "Phase Behavior and Flow Properties of 'Hairy Rod' Monolayers, *Langmuir*, **16**, 726-734